

ITELCO-CLIMA

CLS-CLH control

2 Compressors

ELECTRONIC SERVICE MANUAL

CLS-CLH ELECTRONIC CONTROL



1 TECHNICAL CHARACTERISTICS

1.1 SPECIFICATIONS

	Typical	Min.	Max.
Supply voltage	12V~	10.8V~	13.2V~
Supply frequency	50Hz/60Hz	-	-
Capacity	11VA	-	-
Insulation class	1	-	-
Protection degree	IPO front panel	-	-
Room temperature	25 °C	0 °C	60 °C
Room humidity (non-condensing)	30%	10%	90%
Storage room temperature	25 °C	-20 °C	85 °C
Storage room humidity (non-condensing)	30%	10%	90%

1.2 ELECTRO-MECHANICAL CHARACTERISTICS

<i>Digital outputs</i> 120/240 V	<ul style="list-style-type: none"> • n° 8 relays 5 A resistive; 1/4 hp 230 VAC; 1/8 hp 125 VAC (basic) • The total current on relays shall not exceed 10A • n° 2 relays 5 A resistive; 1/4 hp 230 VAC; 1/8 hp 125 VAC (expansion)
<i>Analog outputs</i>	<ul style="list-style-type: none"> • n° 2 configurable triac outputs or 4-20 mA
<i>Analog inputs</i>	<ul style="list-style-type: none"> • n° 4 NTC R₂₅ 10KΩ • n° 2 configurable inputs 4-20 mA / NTC R₂₅ 10KΩ
<i>Digital inputs</i>	<ul style="list-style-type: none"> • n° 11 voltage-free digital inputs (basic) • n° 4 voltage-free digital inputs (expansion)
<i>Terminals and connectors</i>	<ul style="list-style-type: none"> • n° 1 HV 10-way connector pitch 7.5 • n° 2 LV 16-way connectors pitch 4.2, AWG 16-28 • n° 1 p2,5 5-way connector, with remote control and memory card, AWG 24-30 • n° 1 20-way connector, connection expansion • n° 1 3-way screw terminal for remote keyboard
<i>Display and led</i>	<ul style="list-style-type: none"> • n° 3 digits + sign • n° 5 red LED's
<i>Keys</i>	<ul style="list-style-type: none"> • n° 2 keys
<i>Serial lines</i>	<ul style="list-style-type: none"> • n° 1 serial line 9600 • n° 1 serial line 2400

Transformer

This appliance must be powered by a suitable transformer, having the characteristics listed below:

- Primary voltage: 230V~±10%, 110V~±10%
- Secondary voltage: 12V~
- Supply frequency: 50 Hz; 60 Hz
- Power: 11VA

1.3 DIMENSIONS

- Dimensions: Front 76x34, depth 58 mm
- Container: plastic resin
PC+ABS,extinction degree Vo
- Mounting: panel – on a 71x29 mm hole

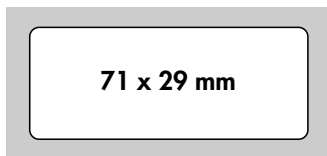

1.4 STANDARDS

The product conforms to the following EC Directives:

- 73/23/EC Directive and subsequent amendments
- 89/336/EC Directive and subsequent amendments and complies with the following harmonised Standards:
- **Low Voltage:** EN60335 as applicable
- **Emission:** EN50081-1 (EN55022)
- **Immunity:** EN50082-1 (IEC 1000-4-2/3/4/5)

2 USER INTERFACE

The interface, consisting of the front of the appliance, allows you to carry out any operation with this tool, and in particular:

- to set the operating mode
- o to control alarm situations
- to check the state of resources

Keyboard

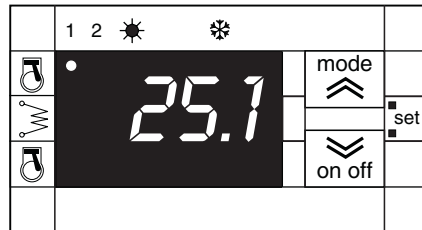

Front panel of the appliance

2.1 KEYS



Mode

Selects the operating mode:

- if the heat mode is enabled, pressing this key results in the following sequence:
Stand-by → *cooling* → *heating* → *stand-by*
- if the heat mode is not enabled:
Stand-by → *cooling* → *stand-by*

In the menu mode, this key becomes the SCROLL UP or UP value (increment) key.



On-Off Alarm Reset

Resets the alarms, and turns the appliance on/off.

Press it once to reset all manual alarms that have not been activated.

Hold this key down for 2 seconds, the appliance switches from ON to OFF or from OFF to ON. When OFF, only the decimal point of the display remains lighted.

In the menu mode, this key becomes the SCROLL DOWN or DOWN (decrement) key.



On-off mode combination

The "mode" and "on-off" keys are pressed at the same time.

Press and release these keys in 2 seconds to go to the lower level in the display menu. Hold down both keys for more than 2 seconds to go to the upper level.

If you are displaying the last level of a menu, pressing and releasing this key in 2 seconds allows you to go to the upper level.

2.2 DISPLAYED DATA

This device can give any type of information on its status, configuration and alarms, through a display and the LED's on its front panel.

2.2.1 DISPLAY



The following data appear in normal display mode:

- the control temperature, in tenths of a degree Celsius with decimal point or Fahrenheit without decimal point.
- The alarm code, if at least one of them is enabled. If more alarms are activated, the first one is displayed, according to the Alarm Table.
- If the thermoregulation is not based on analog inputs and depends on the status of a digital input (ST1 or ST2, configured as digital inputs) the "On" or "Off" label is displayed according to the thermoregulator state (on/off).
- In the menu mode the display is a function of the position.
- If only the decimal point is lighted, the control is not activated. Press the key  for 5 seconds to activate the control, once the machine has been powered.

You will display the value of the sensor of the water entering the evaporator (ST1). To turn off the control, press the key for 5 seconds.



Led 1 compressor 1.

- ON if compressor 1 has been activated
- OFF if compressor 1 is not activated

Defrost

Signalled by the slow blinking of both the LED's of the compressors



Resistor /boiler LED

- ON if the internal antifreeze resistor or the boiler are on
- OFF if the internal antifreeze resistor or the boiler are off



Heating LED

- ON if the device is in heating mode (the reversal valve is not excited)



Cooling LED

- ON if the controller is in cooling mode (the reversing valve is excited)

If the HEAT and COOL LED's are off, the controller is in the STAND-BY mode.



2.3 BEFORE START-UP

Before starting this appliance:

- 1) Turn on the master switch of the supply line.
- 2) For a perfect heating of the oil in the compressor's sump and for a proper removal of the refrigerant contained in the oil, the operation described in point 1) above should be carried out several hours before the actual start-up of the appliance.

2.4 STARTING AND USING THE UNIT

In order to use this unit properly and in full safety, carefully read and understand the following instructions.

- 1) **To start up the unit**, press the  key for 5 seconds; if you do this during operation, the unit will stop. When the appliance is off, the display of the control system shows a red "-" or the E00 message, if a Start/Stop remote contact is provided. While the unit is running, the display shows the temperature of the return water.
- 2) If the unit is of the heat pump type, the  key makes it possible to select the cooling mode or the heating mode. Pressing this key makes the mode cyclically switch from stand-by to cooling, heating, stand-by etc. The cooling mode is indicated by the lighting up of the LED under the ideogram ❄️, while the heating mode is indicated by the lighting up of the LED under the ideogram ☀️.
- 3) **To modify the set point**, press both keys at the same time. When the "Set" message appears on the display, the operation must be repeated to go to the next level. Scroll the text on the display up or down, so that the "Coo" and "HEA" messages appear alternately. The heating set point can be modified by pressing both keys at the same time, so as to go to the next level.

The shop setting will thus appear (12 °C). This setting can be increased or decreased by scrolling the value up or down with the relevant keys.

Once the desired value is displayed, simply press both keys for 2 seconds to accept it and to go back to the previous level.

Scroll the text on the display until the "HEA" message appears and the heating set point can be modified by following the procedure adopted to modify the cooling set point.

Once the set points have been modified, you can go back to the first level by holding both keys down for 2 seconds, as described in the paragraph "User interface".

- 4) **To display other useful temperatures**), go to level 1 as described above and then scroll the display until "tp" appears; then repeat the procedure, so as to reach the lower level. At this point, scroll the display until t01, t02, t03 appears.
If you go to the next level while t02 appears and the leaving water temperature is displayed, while if you repeat the operation when tp03 appears, the coil's surface temperature is displayed.
- 5) The unit is shop-preset for the summer/winter switch over through the keyboard. If **a summer/winter switch over remote contact** is provided, switch the H49 software parameter to reconfigure the unit accordingly.
To do this, press the two keys at the same time to go to the upper level and then scroll the display until "Par" appears. Press both keys at the same time again, so as to go to the upper level, and then scroll the display until "Cnf" appears and repeat the operation to go to the upper level.
Once this level is reached, scroll the display until "H49" appears; at this point press the two keys again to reach the lower level.
At this point modify the setting of the parameter (0 to 1). Confirm the change and repeat the procedure (holding the keys down for 2 seconds each time), so as to go back to the first level.
- 6) In case of summer/winter switch over through a remote contact, **the unit works in cooling mode when the contact is closed and in heating mode when the contact is open.**



IMPORTANT

If the unit is powered with 3-phase voltage, it is essential that the compressor turn in the exact direction. The direction of rotation of scroll compressors is forced. The direction of rotation is wrong when, while the unit is running:

- you hear an anomalous noise of the compressor
- there is not a proper differential between the discharge and the suction pressures (i.e. if the discharge pressure is slightly higher than the suction pressure).

If you exchange the connections of two of the three phases, the compressor inverts the direction of rotation and these phenomena disappear.

2.5 REMOTE KEYBOARD

The *remote display keyboard* is a perfect copy of the information displayed about the instrument, and has the same LED's:

Remote keyboard

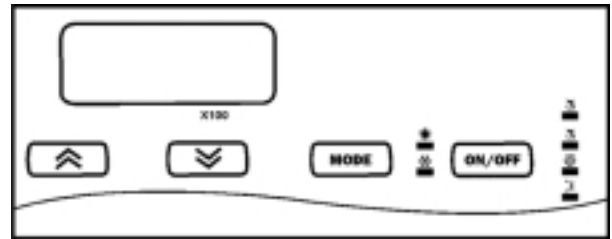

The functions are identical to those listed in the *key and display* section.

The only difference consists in the use of the UP and DOWN keys (to increase/decrease the value), separated by the MODE and ON/OFF keys.

The connection to the device is as follows:

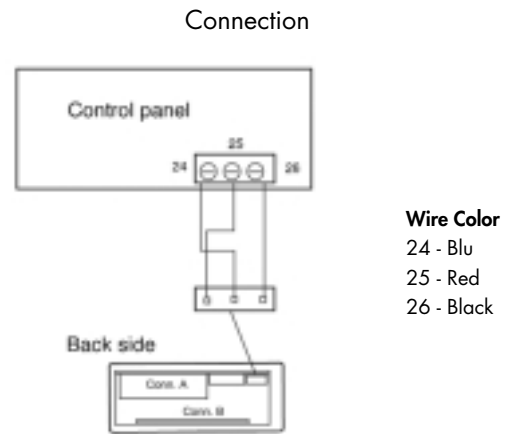

2.6 PARAMETER PROGRAMMING - MENU LEVELS

The parameters of the device can be modified via Personal Computer (through the relevant software, interface module and adequate cables) or via keyboard.

In this case, the access to the different parameters is organized in sub-levels, that can be accessed by pressing the "mode" and "on-off" keys at the same time (see above).

Each menu level is identified by a mnemonic code that appears on the display.

The structure is organized in the manner described in the following diagram:

To enter these parameters, hold down the "Mode - On-Off" keys at the same time for the seconds indicated below:

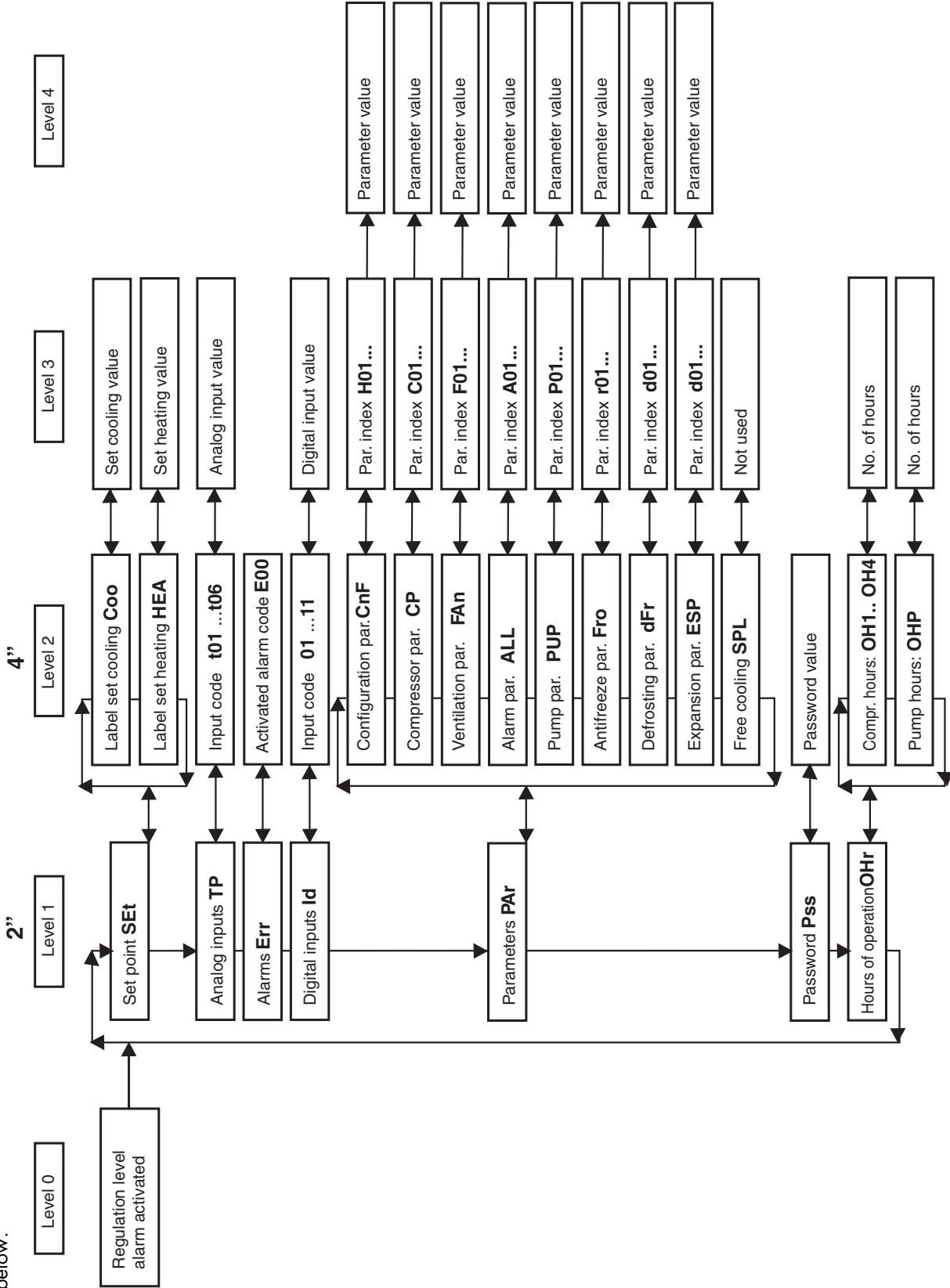

To store the set data, repeat the operations carried out to enter the parameters, but in reverse, until the initial display; in this way you can also store the data.

2.7 PARAMETERS

2.7.1 Set = Setpoint (see the tree menu)

The 2 available setpoints are:

Set	Meaning	Min	Max	Standard
Coo	Cooling Setpoint	7.0	25.0	10.0
HEA	Heating Setpoint	25.0	47	40.0

The 2 setpoints are under Set, by scrolling the menu as indicated for the sensors.

2.7.2 tP = Temperature display

The terminal displays always the temperature of the sensor at the inlet of the evaporator. The other sensors are:

Symbol used for the control	sensor - wiring diagram	meaning
t01	BTin	Temp in evaporator
t02	1BT-out	Temp. at the outlet of evap 1
t03	1BT-coil	Temp of coil 1
t04		
t05	2BT-out	Temp at the outlet of evap 2
t06	2BT-coil	Temp of coil 2

To display the other sensors, press the 2 arrow keys at the same time for 1 second and release them, so as to shift from level 0 to level 1. Use the arrows to go to tP. Press the 2 arrows again for 1 sec. and release these keys to enter level 2 (sensor list) and then level 3 (to read the value of the sensors). To go back to level 0, press the 2 arrow keys at the same time for 3 sec., until you go to the upper level on the display and then release them.

2.7.3 Id = Id = Digital inputs

In this level you can display the state of the digital inputs of the card.

0 = open
1 = closed

CONNECTOR A	ID	Description
	ID1	flow meter/ext consent
	ID2	fans' thermal switch
	ID3	LP1
	ID4	HP1
	ID5	thermal switch C1

CONNECTOR B	ID	Description
	ID6	ON/OFF (can be enabled) Heat/Cold
	ID7	(closed=heat)
	ID8	LP2
	ID9	HP2
	ID10	thermal switch C2
	ID11	free

2.7.4 Par = Parameter level

Enter the parameter list. See the parameter table.

All parameters are divided into 8 groups:

Cnf	parameters H	machine configuration
CP	parameters C	compressor
FAn	parameters F	fans
ALL	parameters A	alarms
PUP	parameters P	pump
Fro	parametersi r	antifreeze/additional resistors
dFr	parameters d	defrosting cycle
ESP	parameters N	card configuration expansion 2 relays

2.7.5 PSS = Password

Enter password 177 to display all the parameters from the parameter list.

2.7.6 OHr = Hours of operation

The hours of operation of compressors and pump are displayed

OH1	Hours of compr. 1
OH3	Hours of compr. 2
OHP	Pump hours

To reset the displayed counter, press the on/off key for 2 seconds while the hours are being displayed. After 999 hours, the decimal point is displayed and the numbering is expressed in hours/100.

2.8 PARAMETER TABLE

The following list shows all the parameters.

CONFIGURATION PARAMETERS*				
Par.	Description	Value	Limits	Unit
Pa G01	"Cooling" set-point	10	7 ÷ 25	°C
Pa G02	"Heating" set-point	40	25 ÷ 47	°C
Pa H01	Max. set-point in heat	47	Pa H02 ÷ 90.0	°C
Pa H02	Min. set-point in heat	25	-40.0 ÷ Pa H01	°C
Pa H03	Max. set-point in cool	25	Pa H04 ÷ 90.0	°C
Pa H04	Min. set-point in cool	7	-40.0 ÷ Pa H03	°C
Pa H05	Number of circuits of the machine	2	0 ÷ 2	Num
Pa H06	Number of compressors per circuit	1	0 ÷ 4	Num
Pa H07	Number of capacity steps per compressor	0	0 ÷ 3	Num
Pa H08	Compressors' start-up sequence	0	0 ÷ 1	Flag
Pa H09	Circuit balancing	0	0 ÷ 1	Flag
Pa H10	Presence of the heat pump	1	0 ÷ 1	Flag
Pa H11	Configuration ST1	1	0 ÷ 4	Num
Pa H12	Configuration ST2	1	0 ÷ 2	Num
Pa H13	Configuration ST3	1	0 ÷ 5	Num
Pa H14	Configuration ST4	0	0 ÷ 3	Num
Pa H15	Configuration ST5	1	0 ÷ 1	Num
Pa H16	Configuration ST6	1	0 ÷ 4	Num
Pa H17	Full scale pressure value	300	0 ÷ 350	kPa* 10
Pa H18	Polarity ID1 ID2 ID3 ID4	15	0 ÷ 15	Num
Pa H19	Polarity ID5 ID6 ID7 ID8	15	0 ÷ 15	Num
Pa H20	Polarity ID9 ID10 ID11 ST4	15	0 ÷ 15	Num
Pa H21	Polarity ST1	0	0 ÷ 1	Flag
Pa H22	Polarity ST2	0	0 ÷ 1	Flag
Pa H23	Configuration ID1	1	0 ÷ 22	Num
Pa H24	Configuration ID2	8	0 ÷ 22	Num
Pa H25	Configuration ID3	12	0 ÷ 22	Num
Pa H26	Configuration ID4	10	0 ÷ 22	Num
Pa H27	Configuration ID5	4	0 ÷ 22	Num
Pa H28	Configuration ID6	2	0 ÷ 22	Num
Pa H29	Configuration ID7	3	0 ÷ 22	Num
Pa H30	Configuration ID8	13	0 ÷ 22	Num
Pa H31	Configuration ID9	11	0 ÷ 22	Num
Pa H32	Configuration ID10	6	0 ÷ 22	Num
Pa H33	Configuration ID11	0	0 ÷ 22	Num
Pa H34	Configuration ST4 (if digital input)	0	0 ÷ 22	Num
Pa H35	Configuration of relay 2	10	0 ÷ 11	Num
Pa H36	Configuration of relay 3	7	0 ÷ 11	Num
Pa H37	Configuration of relay 4	5	0 ÷ 11	Num
Pa H38	Configuration of relay 5	1	0 ÷ 11	Num
Pa H39	Configuration of relay 6	0	0 ÷ 11	Num
Pa H40	Configuration of relay 7	3	0 ÷ 11	Num
Pa H41	Polarity RL2	0	0 ÷ 1	Flag
Pa H42	Polarity RL3	0	0 ÷ 1	Flag
Pa H43	Polarity RL4	0	0 ÷ 1	Flag
Pa H44	Polarity RL5	1	0 ÷ 1	Flag
Pa H45	Alarm relay polarity	0	0 ÷ 1	Flag
Pa H46	Output configuration - fan 1	0	0 ÷ 1	Flag
Pa H47	Output configuration - fan 2	0	0 ÷ 1	Flag
Pa H48	Free	0	0 ÷ 1	Flag
Pa H49	Selection of the operating mode	0	0 ÷ 1	Flag
Pa H50	Enable the dynamic set-point	0	0 ÷ 1	Flag
Pa H51	Offset in cooling - dynamic set-point	8	-50.0 ÷ 80.0	°C

Pa H52	Offset in heating - dynamic set-point	40	-50.0 ÷ 80.0	°C
Pa H53	Set ext. T. in cooling - dynamic set-point	35	-127 ÷ 127	°C
Pa H54	Set ext. T. in heating - dynamic set-point	-5	-127 ÷ 127	°C
Pa H55	Delta T. ext. - dynamic set-point, cooling	25	-50.0 ÷ 80.0	°C
Pa H56	Delta T. ext. - dynamic set-point	28	-50.0 ÷ 80.0	°C
Pa H57	Offset ST1	0.0	-12.7 ÷ 12.7	°C
Pa H58	Offset ST2	0.0	-12.7 ÷ 12.7	°C
Pa H59	Offset ST3	0.0	-12.7 ÷ 12.7	°C/10-Kpa*10
Pa H60	Offset ST4	0.0	-12.7 ÷ 12.7	°C
Pa H61	Offset ST5	0.0	-12.7 ÷ 12.7	°C
Pa H62	Offset ST6	0	-12.7 ÷ 12.7	°C/10-Kpa*10
Pa H63	0=50 Hz 1=60 Hz	0	0 ÷ 1	Flag
Pa H64	0=°C 1=°F	0	0 ÷ 1	Flag
Pa H65	Serial address - family	0	0 ÷ 14	Num.
Pa H66	Serial address - device	0	0 ÷ 14	Num.
Pa H67	User password	177	0 ÷ 255	Num.
Pa H68	Parameter key password	2	0 ÷ 255	Num.
Pa H69	Keyboard presence	1	0 ÷ 1	Flag

* If the parameters of this category are modified, the controller must be turned off and then on again after each change, in order to ensure a proper operation.

2.9 ALARM PARAMETER TABLE

PARAMETERS ALARM				
Par.	Description	Value	Limits	Unit
Pa A01	Bypass of LP pressure switch from compressor	40	0 ÷ 255	Seconds
Pa A02	No. of interventions/hour LP	3	0 ÷ 255	Num
Pa A03	By pass of pressure switch from pump activation	5	0 ÷ 255	Seconds
Pa A04	Duration of flow meter input activated	2	0 ÷ 255	Seconds
Pa A05	Duration of flow meter input deactivated	2	0 ÷ 255	Seconds
Pa A06	No. of interventions/hour flow meter	0	0 ÷ 255	Num
Pa A07	Bypass of compressor's thermal devices from compressor activation	0	0 ÷ 255	Seconds
Pa A08	No. of interventions/hour of the compressor's thermal devices	1	0 ÷ 255	Num
Pa A09	No. of interventions/hour of the fan's thermal devices	1	0 ÷ 255	Num
Pa A10	Bypass of antifreeze alarm from ON-OFF	0	0 ÷ 255	Minutes
Pa A11	Antifreeze alarm activation set	4	-127 ÷ 127	°C
Pa A12	Antifreeze alarm hysteresis	2.0	0 ÷ 25.5	°C
Pa A13	No. of interventions/hour of antifreeze alarm	1	0 ÷ 255	Num
Pa A14	HP activation set for analog input	600	0 ÷ 900	°C/10-Kpa*10
Pa A15	HP hysteresis for analog input	20	0 ÷ 255	°C/10-Kpa*10
Pa A16	Bypass: activation LP for analog input	22	0 ÷ 255	Seconds
Pa A17	Set: activation LP for analog input	-500	-500 ÷ 800	°C/10-Kpa*10
Pa A18	LP hysteresis for analog input	10	0 ÷ 255	°C/10-Kpa*10
Pa A19	No. of interventions/hour LP analog input	4	0 ÷ 255	Num
Pa A20	Uncharged machine differential	20	0 ÷ 255	°C
Pa A21	Uncharged machine bypass	30	0 ÷ 255	Minutes
Pa A22	Uncharged machine time	30	0 ÷ 255	Minutes
Pa A23	Enable the uncharged machine alarm	0	0 ÷ 1	Flag
Pa A24	Enable min. alarm in defrosting	0	0 ÷ 1	Flag
Pa A25	Set over-temperature ST1	25	0 ÷ 255	°C
Pa A26	Duration ON over-temperature 120	120	0 - 255	S*10

2.10 COMPRESSOR PARAMETER TABLE

PARAMETERS COMPRESSOR				
Par.	Description	Value	Limits	Unit
Pa C01	Start/Stop safety time	9	0 ÷ 255	Seconds*10
Pa C02	Start/Start safety time Pa C03 Thermoregulator hysteresis (cooling)	36	0 ÷ 255	Seconds*10
Pa C03	Thermoregulator hysteresis (cooling)	2,5	0 ÷ 25,5	°C
Pa C04	Thermoregulator hysteresis (heating)	2,5	0 ÷ 25,5	°C
Pa C05	Regulation step intervention delta	2,5	0 ÷ 25,5	°C
Pa C06	Interval: compressor - compressor intervention	10	0 ÷ 255	Seconds
Pa C07	Interval: compressor – compressor turning off	0	0 ÷ 255	Seconds
Pa C08	Interval: capacity step intervention	0	0 ÷ 255	Seconds

2.11 VENTILATION PARAMETER TABLE

PARAMETERS VENTILATION				
Par.	Description	Value	Limits	Unit
Pa F01	Fan outlet mode	2	0 ÷ 2	Num
Pa F02	Fan start time	30	0 ÷ 255	Seconds/10
Pa F03	Fan offset	8	0 ÷ 100	µSeconds*200
Pa F04	Start-up pulse duration	3	0 ÷ 255	µSeconds*200
Pa F05	Operation requested by the compressor	0	0 ÷ 1	Flag
Pa F06	Minimum speed in cool	20	0 ÷ 100	%
Pa F07	Max. silent speed in cool	100	0 ÷ 100	%
Pa F08	Set temp./pressure, min. fan speed in cool	100	-500 ÷ 800	°C/10-Kpa*10
Pa F09	Prop. band in cool	50	0 ÷ 255	°C/10-Kpa*10
Pa F10	Cut-off differential	30	0 ÷ 255	°C/10-Kpa*10
Pa F11	Cut-off hysteresis	20	0 ÷ 255	°C*/10-Kpa*10
Pa F12	Cut-off by-pass time	30	0 ÷ 255	Seconds
Pa F13	Max. speed in cool	100	0 ÷ 100	%
Pa F14	Set temp./pressure, max. fan speed in COOL	800	-500 ÷ 800	°C/10-Kpa*10
Pa F15	Min. speed in heat	100	0 ÷ 100	%
Pa F16	Max. silent speed in heat	100	0 ÷ 100	%
Pa F17	Set temp./pressure, min. fan speed in heat	10	-500 ÷ 800	°C/10-Kpa*10
Pa F18	Prop. band in heat	50	0 ÷ 255	°C/10-Kpa*10
Pa F19	Max. speed in heat	100	0 ÷ 100	%
Pa F20	Set temp./pressure, max. fan speed in heat	-200	-500 ÷ 800	°C/10-Kpa*10
Pa F21	Pre-ventilation in cooling mode	0	0 ÷ 255	Seconds
Pa F22	Single or separated ventilation	1	0 ÷ 1	Flag
Pa F23	Set temp./pressure, fan activation in defrosting	800	-500 ÷ 800	°C/10-Kpa*10
Pa F24	Fan activation hysteresis in defrosting	0	0 ÷ 255	°C/10-Kpa*10
Pa F25	Fan time (post-defrosting)	0	0 ÷ 255	Seconds

2.12 PUMP PARAMETER TABLE

PUMP PARAMETERS				
Par.	Description	Value	Limits	Unit
Pa P01	Pump operating mode	0	0 ÷ 1	Flag
Pa P02	Delay: pump ON compressor ON	20	0 ÷ 255	Seconds
Pa P03	Delay: compressor OFF pump OFF	15	0 ÷ 255	Seconds

2.13 RESISTOR PARAMETER TABLE

RESISTOR PARAMETERS				
Par.	Description	Value	Limits	Unit
Pa r01	Resistor configuration in defrosting mode	0	0 ÷ 1	Flag
Pa r02	Resistor (on) configuration in cooling mode	0	0 ÷ 1	Flag
Pa r03	Resistor (on) configuration in heating mode	0	0 ÷ 1	Flag
Pa r04	Configuration of resistor regulating sensor 1	2	0 ÷ 3	Num
Pa r05	Configuration of resistor regulating sensor 2	3	0 ÷ 3	Num
Pa r06	Resistor configuration - OFF or STAND-BY	1	0 ÷ 1	Flag
Pa r07	Set point of resistor 1 in heating mode	5	Pa 10 ÷ Pa 09	°C
Pa r08	Set point of resistor 1 in cooling mode	5	Pa 10 ÷ Pa 09	°C
Pa r09	Max. resistor set	30	Pa 10 ÷ 127	°C
Pa r10	Min. antifreeze resistor set	-10	-127 ÷ Pa 09	°C
Pa r11	Antifreeze resistor hysteresis	2.0	0 ÷ 25,5	°C
Pa r12	External antifreeze resistor set point	1	Pa 10 ÷ Pa 09	°C
Pa r13	Set point of resistor 2 in heating mode	5	Pa 10 ÷ Pa 09	°C
Pa r14	Set point of resistor 2 in cooling mode	5	Pa 10 ÷ Pa 09	°C
Pa r15	Enable resistors in integration	0	0 ÷ 1	Flag
Pa r16	Integration resistor 1 activation	2.0	0 ÷ 25.5	°C
Pa r17	Integration resistor 2 activation	2.0	0 ÷ 25.5	°C

2.14 DEFROSTING PARAMETER TABLE

DEFROSTING PARAMETERS				
Par.	Description	Value	Limits	Unit
Pa d01	Enable defrosting	1	0 ÷ 1	Flag
Pa d02	Defrosting start temperature/pressure	0	-500 ÷ 800	°C/10 - kPa*10
Pa d03	Defrosting interval	45	0 ÷ 255	Minutes
Pa d04	Defrosting end temperature/pressure	60	-500 ÷ 800	°C/10 - kPa*10
Pa d05	Max. defrosting time	5	0 ÷ 255	Minutes
Pa d06	Compressor-reversing valve waiting time	0	0 ÷ 255	Seconds
Pa d07	Dripping time	0	0 ÷ 255	Seconds
Pa d08	Delay between circuit defrosting	0	0 ÷ 255	Secondi *10
Pa d09	Defrosting circuit 1 outlet sensor	1	0 ÷ 3	Num
Pa d10	Defrosting circuit 2 outlet sensor	3	0 ÷ 3	Num
Pa d11	Compressor start-up delay in defrosting	0	0 ÷ 255	Seconds

2.15 EXPANSION PARAMETER TABLE

EXPANSION PARAMETERS				
Par.	Description	Value	Limits	Unit
Pa N01	Polarity ID12 ID13 ID14 ID15	15	0 ÷ 1	Flag
Pa N02	Configuration ID12	0	0 ÷ 19	Num
Pa N03	Configuration ID13	0	0 ÷ 19	Num
Pa N04	Configuration ID14	0	0 ÷ 19	Num
Pa N05	Configuration ID15	0	0 ÷ 19	Num
Pa N06	Relay configuration 9	0	0 ÷ 11	Num
Pa N07	Relay configuration 10	0	0 ÷ 11	Num

3 ALARM TABLE

CODE	SIGNAL	DESCRIPTION	RESET
E00	Remote Off	<ul style="list-style-type: none"> • Turns off all the users; • Is activated by the digital input configured as "remote ON-OFF" (see digital inputs) 	Auto
E01	High pressure in circuit 1	<ul style="list-style-type: none"> • Turns off all the compressors of circuit 1; • Is activated by the digital input configured as "High pressure in circuit 1" (see digital inputs) 	Man
E02	Low pressure in circuit 1	<ul style="list-style-type: none"> • Turns off the compressors and the fans of the condenser if the separate condensation has been set for the 2 circuits (see single or separate condensation); • Is activated by the digital input configured as "Low pressure in circuit 1" (see digital inputs); • Automatically reset until the number of interventions/hour is equal to the value set by parameter Pa A02; in this case it becomes manual; • Disabled during the Pa A01 time counting, due to the turning on of a compressor or by the reversal of the 4-way valve (reversing valve) of circuit 1 	Auto/Man
E03	Thermal protection of compressor 1	<ul style="list-style-type: none"> • Turns off the compressor 1; • Is activated by the digital input configured as "Thermal devices of compressor 1" (see digital inputs); • Automatically reset until the number of interventions/hour is equal to the value set by parameter Pa A07; in this case it becomes manual; • Disabled during the Pa A08 time counting, due to the turning on of the compressor 	Auto/Man
E04	Thermal protection of the condenser's fans - circuit 1	<ul style="list-style-type: none"> • Turns off the fans and compressors of circuit 1; if the single condensation is set for the 2 circuits (see single or separate condensation) the compressors of circuit 2 are locked as well; • Is activated by the digital input configured as "Thermal devices of the fan, circuit 1" (see digital inputs); • Automatically reset until the number of interventions/hour is equal to the value set by parameter Pa A09; in this case it becomes manual; 	Auto/Man
E05	Antifreeze - circuit 1	<ul style="list-style-type: none"> • Turns off the fans and the compressors; • Is enabled if the analog sensor ST2 (see analog inputs) is configured as antifreeze sensor (Pa H12=1); • Is activated when the sensor ST2 detects a value lower than Pa A11; • Is disabled if the sensor ST2 detects a value above Pa A11 + Pa A12; • Automatically reset until the number of interventions/hour is equal to the value set by parameter Pa A13; in this case it becomes manual; • Is disabled during the Pa A10 time counting by the turning on of Energy 400 by the ON-OFF key (see keyboard) or by the ON-OFF digital input (see the digital inputs) or when the heating mode is enabled 	Auto/Man
E06	Failure of sensor ST2	<ul style="list-style-type: none"> • Turns off all the users; • Is enabled if the sensor ST2, configured as analog input, is short-circuited or cut-out or when the sensor limits are exceeded (-50 °C..100 °C) 	Auto
E07	Failure of sensor ST3	<ul style="list-style-type: none"> • Turns off all the users; • Is enabled if the sensor ST3, configured as analog input, is short-circuited or cut-out or when the sensor limits are exceeded (-50 °C..100 °C) 	Auto
E21	High pressure - circuit 2	<ul style="list-style-type: none"> • Turns off the compressors of circuit 2; • Is activated by the digital input configured as "High pressure - circuit 2" (see digital inputs) 	Man

CODE	SIGNAL	DESCRIPTION	RESET
E22	Low pressure circuit 2	<ul style="list-style-type: none"> • Turns off the compressors of circuit 2 and the condenser's fans if the separate condensation for the 2 circuits has been set (see single or separate condensation); • Is activated by the digital input configured as "Low pressure – circuit 2" (see digital inputs); • Automatically reset until the number of interventions/hour is equal to the value set by parameter Pa A02; in this case it becomes manual; • Is disabled during the Pa A01 time counting by the turning on of a compressor or by the reversal of the 4-way valve (reversing valve) of circuit 1 	Auto/Man
E25	Antifreeze - circuit 2	<ul style="list-style-type: none"> • Turns off the fans and the compressors; • Is enabled if the ST5 analog sensor (see analog inputs) is configured as antifreeze sensor (Pa H15=1); • Is activated when sensor ST5 detects a value lower than Pa A11; • Is disabled if sensor ST5 detects a value higher than Pa A11 + Pa A12; • Automatically reset until the number of interventions/hour is equal to the value set by parameter Pa A13; in this case it becomes manual; • Is disabled during the Pa A10 time counting by the turning on of Energy 400 by the ON-OFF key (see keyboard) or by the ON-OFF digital input (see the digital inputs) or when the heating mode is enabled 	Auto/Man
E26	Failure of sensor ST5	<ul style="list-style-type: none"> • Turns off all the users; • Is enabled if the sensor ST5, configured as analog input, is short-circuited or cut-out or when the sensor limits are exceeded (-50 °C..100 °C) 	Auto
E27	Failure of sensor ST6	<ul style="list-style-type: none"> • Turns off all the users; • Is enabled if the sensor ST6, configured as analog input, is short-circuited or cut-out or when the sensor limits are exceeded (-50 °C..100 °C) 	Auto
E 40	Failure of sensor ST1	<ul style="list-style-type: none"> • Turns off all the users; • Is enabled if the sensor ST1, configured as analog input, is short-circuited or cut-out or when the sensor limits are exceeded (-50°C.. 100°C) 	Auto
E41	Flow meter	<ul style="list-style-type: none"> • Turns off all the compressors, the fans and the pump (if of manual reset type); • Is enabled if the digital input configured as "Flow meter" (see digital inputs) remains activated for a time = Pa A04; • Is disabled if the digital input configured as "Flow meter" (see digital inputs) remains activated for a time = Pa A05; • Automatically reset until the number of interventions/hour is equal to the value set by parameter Pa A06; in this case it becomes manual; • Is disabled during the Pa A03 time counting by the activation of the pump 	Auto/Man
E45	Configuration error	<ul style="list-style-type: none"> • Turns off all the users; • The alarm is activated when at least one of these conditions is met: H11=2 (ST1 set as heat request), H12=2 (ST2 configured as cold request) and both inputs are enabled; • the sum of the compressors and the capacity steps of the machine > 4 	Man
E46	High regulation temperature	<ul style="list-style-type: none"> • Turns off all the users, except for the pump; • Is activated if the values of sensor ST1 (see analog inputs) exceeds Pa A25 for a time > Pa A26 in cooling mode; • Is disabled if the values of the sensor ST1 (see analog inputs) are lower than Pa A25 – Pa A12; • The reset is automatic. 	Auto

Manual alarms are reset by pressing the On/Off key for 1 second.

4 CLS-CLH TROUBLE SHOOTING

The following table details possible unit faults, their probable cause and suggested remedies, for any other problems not immediately recognisable and/or technical assistance, call an authorised Technical Service Center.

Faulty	Probable cause	Remedy
E00 Remote Off	Remote on/off contact open Wrong electrical cable connection	Close the contact To check the electrical connection
E01 High pressure (digital) Circuit 1	<u>COOL</u> Fan stop Low ventilation Fan thermal contact open High gas charge Coil dirty Coil obstruct Fault high pressure transducer <u>HEAT</u> Low water flow Wrong pump Dirty filter Dirty exchanger High circuit pressure drop	To check the fan To check the fan speed To reset the contact To check the gas charge To clean the coil To check the installation position To replace the transducer To check the pump To check the pump size To clean the filter To clean the exchanger To check the plant pressure drop
E02 Low pressure (digital) Circuit 1	Expansion valve broken Gas circuit empty Gas leak High temperature water inlet Solenoid valve not open Solenoid valve not open	To replace the expansion valve To charge the circuit To find and repair the leak To check the plant thermal load To check the electrical connection To check Pump Down setting
E03 Thermal switch compressor 1	Motor compressor faulty Compressor thermal contact open Wrong charge Wrong electrical cable connection & phase missing	To check the compressor motor To reset the thermal contact To check the gas charge To check the electrical connection, to tighten the terminal block screws
E04 Thermal switch fans	Fan stop Fan thermal contact open Fan blocked Wrong electrical cable connection & phase missing	To check the motor To reset the thermal contact and to check the scale To release the fan To check the electrical connection, to tighten the terminal block screws
E05 Antifreezing Circuit 1	Low water flow Wrong pump Water filter dirty Dirty exchanger High circuit pressure drop	To check the pump To check the pump size To clean the filter To clean the exchanger To check the plant pressure drop
E06 Failure sensor ST2 Outlet water temperature	Faulty sensor Cut cable Sensor not connected Water inside the sensor	To replace the sensor To replace cable To check the electrical connection To check the insulation
E07 Failure sensor ST3 Coil 1	Faulty sensor Cut cable Sensor not connected Water inside the sensor	To replace the sensor To replace cable To check the electrical connection To check the insulation

Faulty	Probable cause	Remedy
E 21 High pressure (digital) Circuit 2	<u>COOL</u> Fan stop Low ventilation Fan thermal contact open High gas charge Coil dirty Coil obstruct Fault high pressure transducer <u>HEAT</u> Low water flow Wrong pump Dirty filter Dirty exchanger High circuit pressure drop	To check the fan To check the fan speed To reset the contact To check the gas charge To clean the coil To check the installation position To replace the transducer To check the pump To check the pump size To clean the filter To clean the exchanger To check the plant pressure drop
E 22 Low pressure (digital) Circuit 2	Expansion valve broken Gas circuit empty Gas leak High temperature water inlet Solenoid valve not open Solenoid valve not open	To replace the expansion valve To charge the circuit To find and repair the leak To check the plant thermal load To check the electrical connection To check Pump Down setting
E 25 Antifreezing Circuit 2	Low water flow Wrong pump Water filter dirty Dirty exchanger High circuit pressure drop	To check the pump To check the pump size To clean the filter To clean the exchanger To check the plant pressure drop
E 26 Failure sensor ST5 Outlet water temperature	Faulty sensor Cut cable Sensor not connected Water inside the sensor	To replace the sensor To replace cable To check the electrical connection To check the insulation
E 27 Failure sensor ST6 Coil 2	Faulty sensor Cut cable Sensor not connected Water inside the sensor	To replace the sensor To replace cable To check the electrical connection To check the insulation
E 40 Failure sensor ST1 Inlet water temperature	Faulty sensor Cut cable Sensor not connected Water inside the sensor	To replace the sensor To replace cable To check the electrical connection To check the insulation
E 41 Flow switch	Water pump stop Water pump blocked Pump thermal contact open Flow switch blocked	To check the pump To release the pump To reset the thermal contact and to check the scale To release the flow switch
E45 Configuration error	Wrong configuration	To check the configuration with spec.
E46 Over temperature	Small refrigerator capacity Sensor out of the socket	To check the plant thermal load To check the sensor socket

TERMINAL BOARDS FOR USER CONNECTIONS

QG - Y1

